



PRECISION GAGE & TOOL COMPANY

Precisionaire® Gaging

The Sheffield Precisionaire® Column from Precision Gage & Tool is the industry's most accurate, dependable, and widely accepted air instrument. While its truly modular design is adapted to the same proven principles used for many years, today's models are improved and simplified for increased reliability and operator convenience.

Versatility

Modular design means that complete instruments in any combination of columns and amplifications can be assembled in minutes.

Amplification is entirely pneumatic and linear over the full scale. Amplifications from 62.5 to 1 up to 40,000 to 1 are available. The graduated scales enable maximum and minimum tolerance limits to be set to allow plenty of "come-up" and "go-beyond" for accurate, easy reading.

Dramatically lower costs

With dependable air gaging, scrap is reduced, no usable parts are rejected—and many out-of-tolerance parts are salvageable. Because inspection time is shortened, overall production time is reduced and machining processes can be brought under control more quickly.

In many cases, costly high-skill man hours can be better utilized, as air gaging requires a minimum of operator training and skill. Finally, air gage size-sensing elements outlast conventional limit-type gages many times, and, unlike many ordinary gaging methods, air gaging allows easy compensation for gage wear.

See companion Precisionaire Gaging Price List for more details, part numbers and prices.

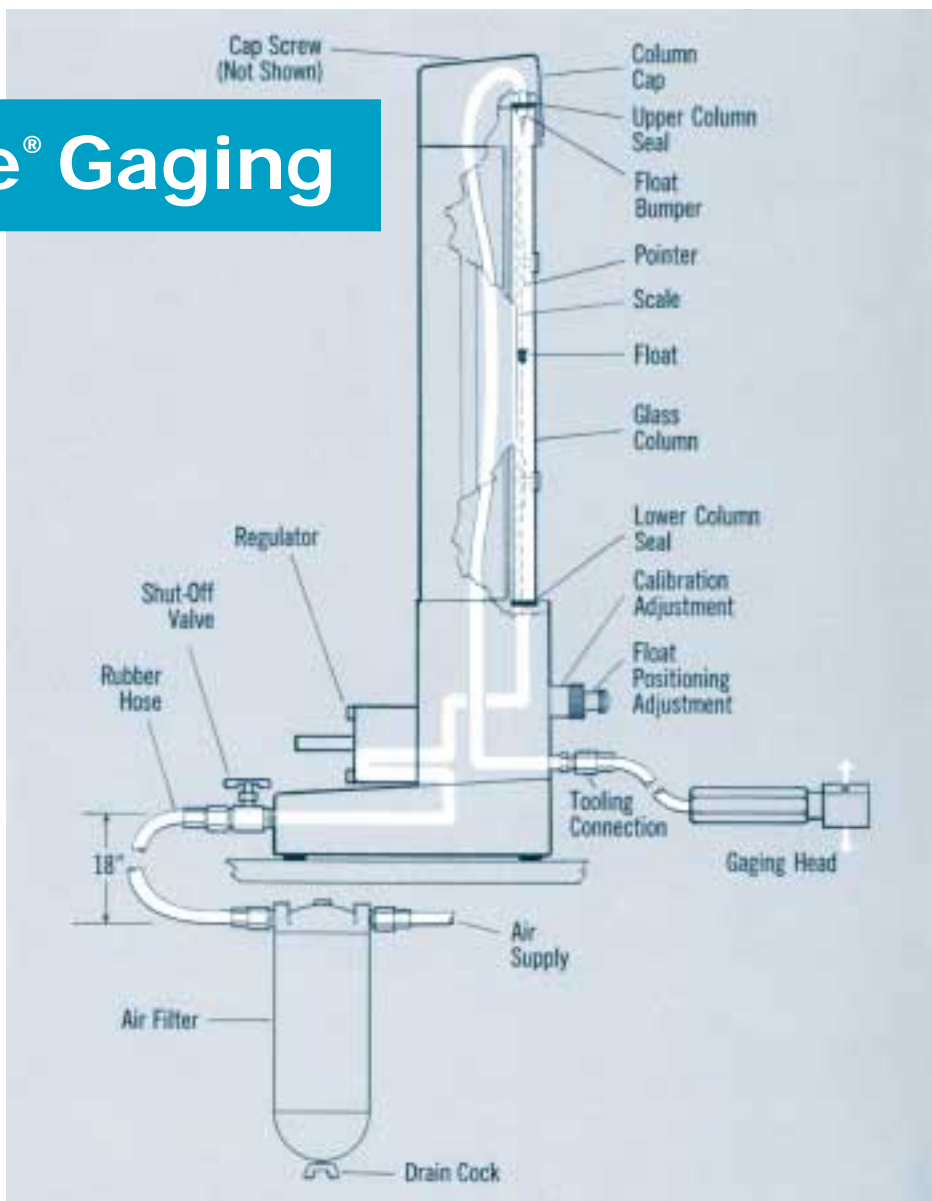

Less time, greater accuracy

All gaging systems using Precisionaire Instruments can accurately inspect up to 40 or more part dimensions in the same time it takes to check one dimension with a conventional gage. Side-by-side columns form a "float graph" which can be viewed instantly. Conditions and relationships such as average diameter, camber, squareness and other measurements which are extremely difficult to check are readily measured by Precisionaire systems.

Principle of operation

The Precisionaire Column Instrument is essentially an air flow indicator. Pressurized air suspends a float in a transparent tube; this float moves up and down in the tube according to the flow of air.

From the top of the tube, the air flows through a hose and exhausts through the clearance between the gaging device and the workpiece. The rate of air flow is proportional to the clearance, which is indicated directly by the position of the float in the column.

Precise amplification and linearity are permanently built-in; the only moving part is the float supported on a column of air. The easy-to-read scale shows size at a glance.

Calibration

Appropriate setting masters are used to establish the upper and lower limits of float travel in the column. These represent minimum and maximum part tolerance limits. Proper float travel between these limits are regulated by the external float positioning and calibration adjustments.

Internal or external measurement

A typical gaging spindle has a central air passage and diametrically opposed air jets. It gages the true diameter of a hole based on the amount of clearance between the spindle and part inside diameter (I.D.); any change in air flow is directly indicated as a dimension by the float's position in the glass tube relative to the instrument's scale.

In the case of internal diameters, master setting rings have internal diameters equivalent to the minimum and maximum part tolerance limits and are used for calibration. For external checking, Airsnaps or Air Rings, with opposed jets, gage the part to indicate dimensional size. Master setting discs with external diameters equivalent to minimum and maximum part tolerance limits are used for calibration.

Single or multi-column flexibility

Modular Precisionaire Instruments can be adapted as desired for single or multiple, internal and external dimensional measuring. This modular "building block" design enables small, as well as, large shops to meet on-the-job inspection requirements with flexibility, speed, and economy. The modular columns and base panels can be stocked in the tool crib, ready to assemble quickly for immediate use.

Precisionaire Column Instruments can be used with all existing or new standard and special tooling without alteration. Standard 9" models are available in amplifications of 1,000, 2,000, 5,000, 10,000, 20,000 and 40,000 to 1; standard 15" models are available only in amplifications of 5,000 and 10,000 to 1. Conversion kits can be supplied for quick change to any standard amplification.



Tolerance and Range Table*

Amplification	Full Scale		Recommended		Each Graduation
	Range	Spread	Range	Spread	
1,000/1	.0075	7-1/2"	.005	5"	.0002
2,000/1	.0045	9"	.003	6"	.0001
5,000/1	.0018	9"	.0012	6"	.00005
10,000/1	.0009	9"	.0006	6"	.000020
20,000/1	.00045	9"	.0003	6"	.000010
40,000/1	.000225	9"	.00015	6"	.000005







*While the above shows the maximum recommended tolerance and spread, it is good gaging practice to use from 2 to 4 inches for the tolerance spread, which permits plenty of "come-up" and "go-beyond" outside the tolerance spread.









Conversion Kit

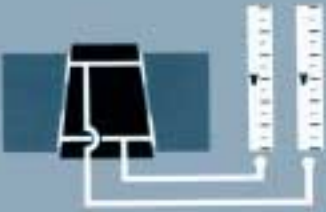

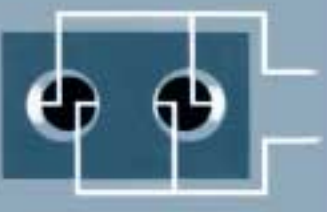
Convert modular Precisionaire Column Instruments from one amplification to another in minutes. The Precisionaire Conversion Kit contains everything you need, including column seals, float bumper assemblies, float, glass tube and appropriate scales. Kits are available for the following amplifications: 1000 • 2000 • 5000 • 10,000 • 20,000 • 40,000.

Dimensions and Conditions

TRUE DIAMETER			OUT-OF-ROUND		AVERAGE DIAMETER
					
Use standard spindles with two opposed jets for tolerances of .005 or less; surface finish of 63 microinches or better.	Leafjet spindles are used for tolerances greater than .005, where holes have interruptions such as keyways, or to check to the extreme bottom of a hole.	Use Balljet spindles to check holes with porous surfaces, short lands and thru holes to very edge.	A diametrically opposed out-of-round condition is indicated when any spindle is rotated through 90°.		Order a spindle with three or more evenly spaced jets.

BELL-MOUTH	TAPER	CONCENTRICITY	CENTER DISTANCE
			
Bell-mouth is indicated as any spindle enters or is withdrawn from a bore.	Indicated as any spindle passes through a bore. Or use a special two-circuit spindle.	Use an engineered locating fixture containing opposed Airejets for checking concentricity by gaging wall thickness.	Use a fixture which integrates two spindles, each with 2 opposed Airejets.

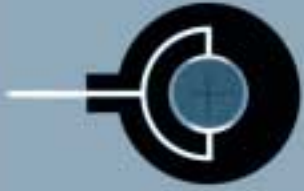
AXIS TO FACE SQUARENESS	CAMBER	PARALLELISM
		
Squareness is measured by rotating the part 180° around a special spindle having opposed orifices.	Rotate a special four-jet spindle 180° to check the camber or straightness.	Two integrated spindles, as used for checking axis to face squareness, can be used in an engineered fixture.

TRUE DIAMETER	OUT-OF-ROUND	TAPER
		
Use standard Air Rings for parts with tolerances of .005 or less, and a surface finish of 63 microinches or better.	Use standard Airsnap with opposed jets where tolerance is .002 or less, and surface finish is 63 microinches or better.	Airejets can be used to check tapered parts.

AVERAGE DIAMETER



Indicated with an Air Ring with three or more jets.

AXIS TO FACE SQUARENESS

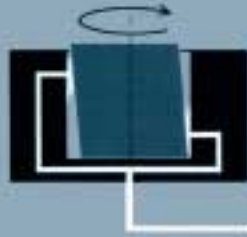

Check squareness with engineered Air Ring or a fixture.

CLEARANCE



Proper mating of parts is facilitated with a 3-column instrument, arranged to show inside diameter (I.D.), outside diameter (O.D.) and clearance.

CAMBER OR BEND



Use an engineered Air Ring.

DIMENSIONS



Airejets may be used with fixtures to check virtually any dimensions in production work.

THICKNESS



Use 2 opposed Airejets or Balljet cartridges.

SQUARENESS



Squareness fixtures can incorporate Airejet, Balljet or Leafjets.

INSIDE WIDTH



Various internal dimensions can be checked with engineered Airejet Spindles.

MULTIPLE CHECKING

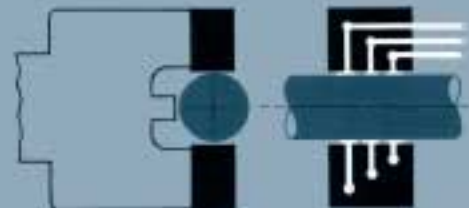

Airsnap can be engineered for simultaneous inspections of diameters at several points.

SIMULTANEOUS MULTIPLE CHECKING

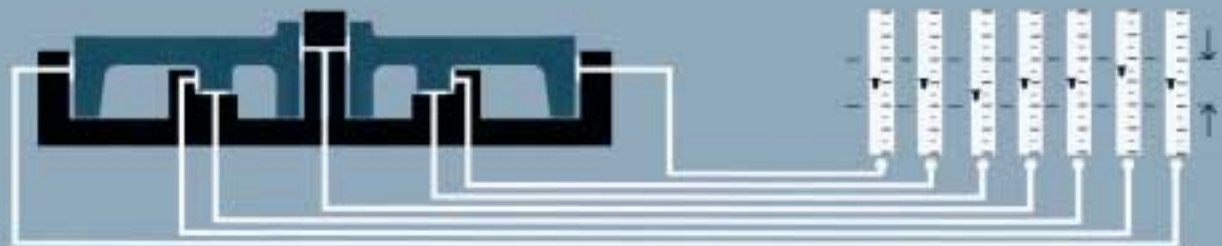

For production checking of precision parts, Precision Gage & Tool can combine in a single gage any of the components and principles in this catalog. Inspectors see at a glance whether the part passes and the amount of any deviation.

Modular Precisionaire® Scales

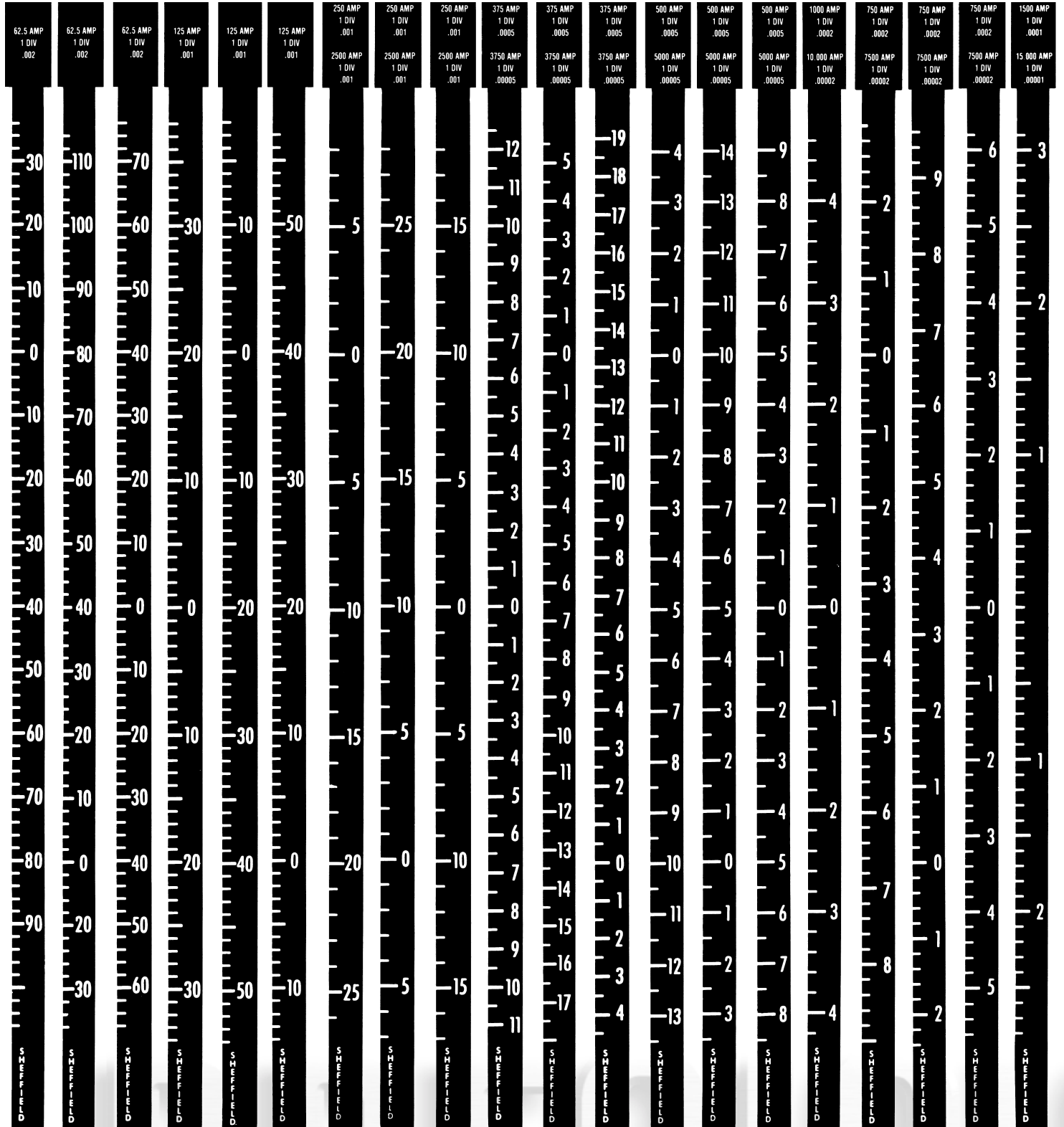

A B C D E F G H I J

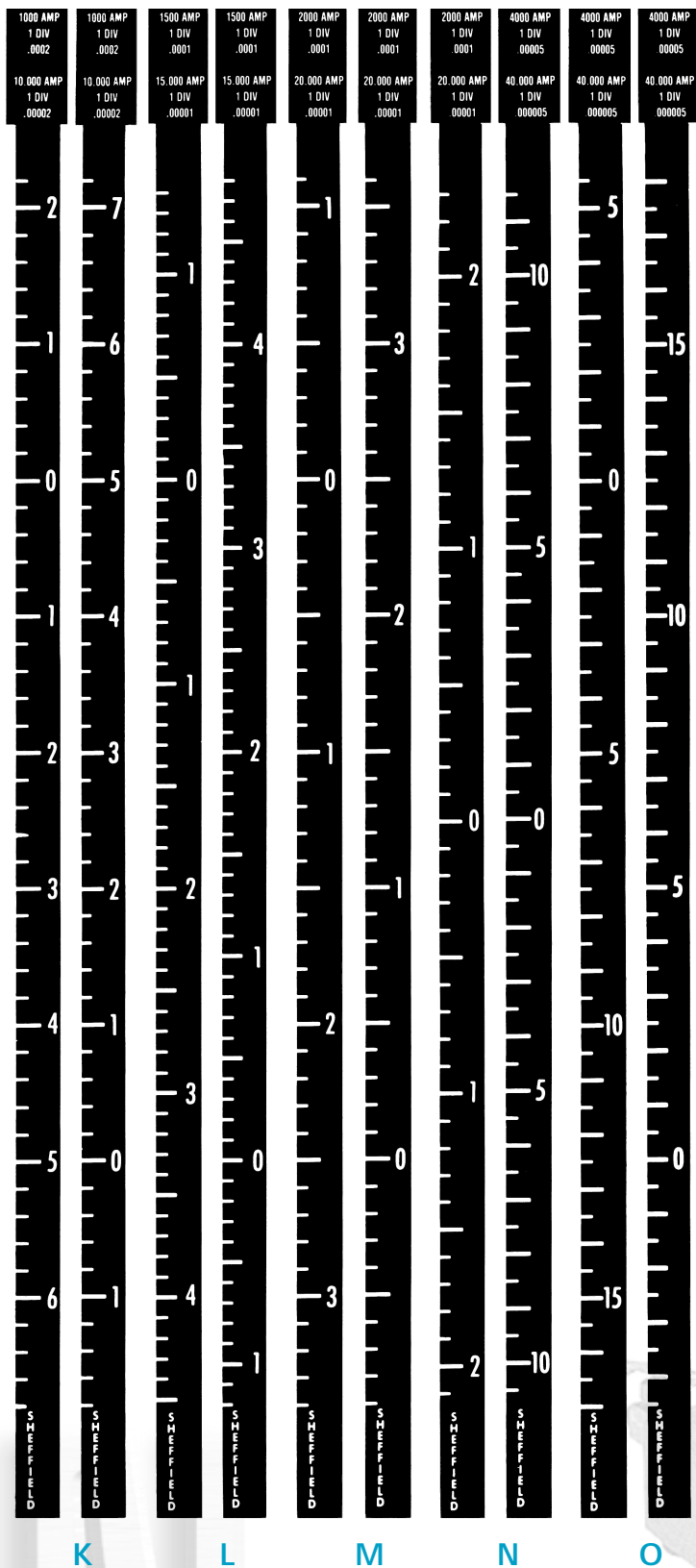

Single Column Modular Precision® Instruments are furnished with standard External ("0" High) and Internal ("0" Low) scales. "0" Center scales may be substituted on request at no extra cost. All scales are right hand and are imprinted on both sides of the scale plate.

Where a higher amplification is 10 times that of another, the scale provided includes both amplifications on one scale. Scales are available in amplifications to cover all tooling and tolerance requirements:

Standard Amplifications

- 1,000 to 1
- 2,000 to 1
- 5,000 to 1
- 10,000 to 1
- 20,000 to 1
- 40,000 to 1

Amplification for Special Applications

- 62.5 to 1
- 125 to 1
- 250 to 1
- 375 to 1
- 2,500 to 1
- 4,000 to 1

Three-Quarter Amplifications

- 1,500 to 1
- 3,750 to 1
- 7,500 to 1
- 15,000 to 1

Scales for 15" Models are available in all amplifications and styles except 62.5 amplification.

Key	Order No.	Amplification	Style
A	60108586	62.5	"0" High
		62.5	"0" Low
B	60108576	62.5	"0" Center
		125	"0" Center
C	60108587	125	"0" High
		125	"0" Low
D	60108588	250 & 2500	"0" High
		250 & 2500	"0" Low
E	60108577	250 & 2500	"0" Center
		375 & 3750	"0" Center
F	60108589	375 & 3750	"0" High
		375 & 3750	"0" Low
G	60108590	500 & 5000	"0" High
		500 & 5000	"0" Low
H	60108578	500 & 5000	"0" Center
		1000 & 10,000	"0" Center
I	60108591	750 & 7500	"0" High
		750 & 7500	"0" Low
J	60108579	750 & 7500	"0" Center
		1500 & 15,000	"0" Center
K	60108592	1000 & 10,000	"0" High
		1000 & 10,000	"0" Low
L	60108593	1500 & 15,000	"0" High
		1500 & 15,000	"0" Low
M	60108594	2000 & 20,000	"0" High
		2000 & 20,000	"0" Low
N	60108580	2000 & 20,000	"0" Center
		4000 & 40,000	"0" Center
O	60108595	4000 & 40,000	"0" High
		4000 & 40,000	"0" Low

Tooling and Components

Presenting Spindle to the Work

Where the spindle is presented to the work, the following components are required:

- connector with two "O" rings
- handle
- hose assembly including fittings at each end

A backstop may be used, making it easy to check to a specified depth.

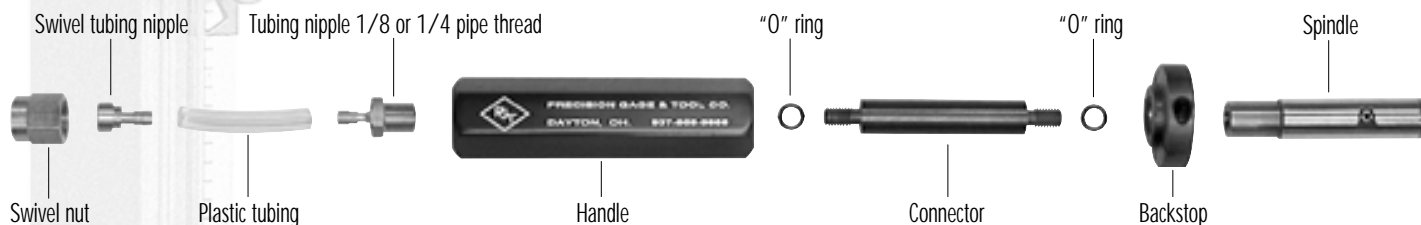

Presenting Work to the Spindle

Where work is presented to the spindle, the following components are required:

- gaging stand (which permits spindle to be used either in a horizontal or vertical position)
- backstop
- connector with two "O" rings
- spacer
- hex nut
- 90° elbow
- hose assembly with fittings

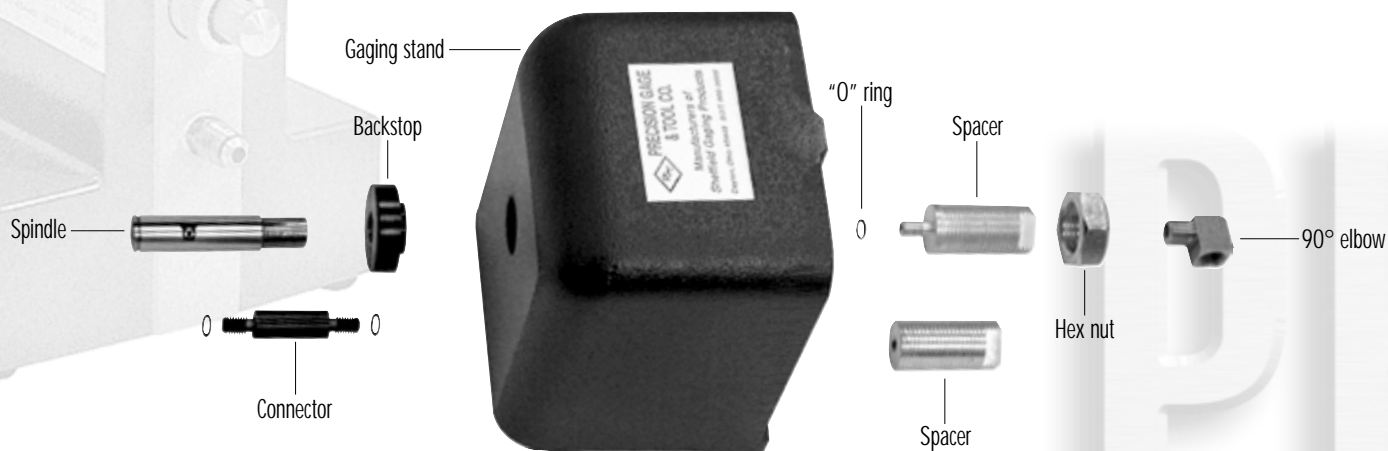

Standard Spindles

Standard Airejet Spindles, Sizes .296 - 4.000

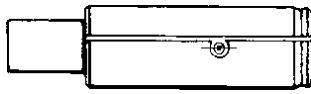

Thru Hole Type

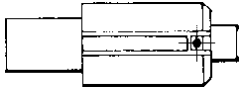

Blind Hole Type

Airejet Spindles with diametrically opposed, standard size jets are used for inspecting bore diameters above .296 through 4.000. Two types are offered: thru hole and blind or counterbored hole. The blind hole type may also be used for checking thru holes. Available standard material is long wear life steel, with optional heavy chrome plating or titanium nitride (TiN) coating for increased wear life.

Spindles larger than a 4.000 diameter, spindles with three or more jets for checking average diameter and "clover-leaf" or lobed conditions, and spindles of special lengths, shapes, etc. are available on special order. When ordering, designate desired spindle, components, instrument type and amplification.

Standard Small Jet Spindles, Sizes .296 - .859

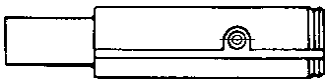

These are the same as Standard Airejet Spindles in the range .296 through .859 except that a smaller size jet is used. This permits checking of narrow lands, thinner parts, and closer to the bottom of blind holes. They are used with Precisionaire Instruments of 2,000 to 1 amplification or higher, and will achieve 3/4 of basic amplification. Use with an Air to Electronic (A/E) Column to obtain full amplification. Maximum part tolerance is .0025.

Standard Small Jet Spindles, Sizes .1250 - .2960

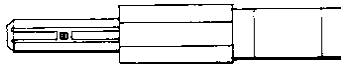

Standard Small Jet Spindles in the range .1250 through .2960 are different in design than those of standard spindles above .2960. Spindles for this size range are available as standard in long wear life steel and can be TiN coated. These spindles are used with Precisionaire Instruments having amplifications of 2,000 to 1 or higher and achieve 3/4 of the basic amplification. For full amplification, use with an A/E Column. Maximum part tolerance is .0025.

Standard Small Jet Spindles, Sizes .093 - .1250

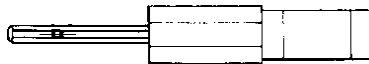

Small Jet Spindles in the .093 through .1250 range are made of long wear life steel and can be TiN coated. These spindles are used with Precisionaire Instruments having amplifications of 5,000 to 1 or higher and achieve 1/5 of the basic amplification. For full amplification, use with an A/E Column. Maximum part tolerance is .0005.

When ordering, please send a detailed part print so that our application engineers can double check your requirements.



Balljet Spindles

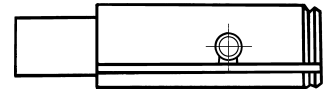

Balljet Spindles are recommended for gaging I.D.'s in soft or porous parts, for narrow lands and for gaging bores to the hole edge. Standard Balljet Spindles are stocked in semi-finished blanks ranging from .375 to 2.000 for thru and blind holes. Standard material is long wear steel. Engineered Balljet Spindles are available. Maximum part tolerance is .0025.

Leafjet Spindles

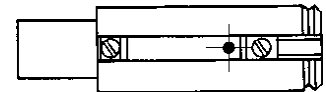

Leafjet Spindles are semi-standard, contact-type spindles for checking laminated bores, rough surfaces and for gaging thru or blind holes in which oil grooves, keyways or cross-drilled holes prevent the use of standard Airejet Spindles.

Leafjet components are stocked and spindles are made to size per order. Leafjet Spindles are for checking hole diameters .4375 and larger and may be designed for checking tolerances in excess of those possible with Airejet and Balljet Spindles. They can also be used for checking to the extreme bottom of blind holes and to the extreme edge of holes and grooves.

Airsnap and Air Rings

Fixed "C" Type Airsnaps

Semi-finished frames of fixed "C" Type Airsnaps for part tolerances of .0005 and above are stocked for sizes .500 through 4.500. Maximum diameter of the part determines Airsnap size. The centerline of the elongated jet is .187 from the side of the Airsnap.

Engineered Airsnaps are available for sizes larger or smaller than standard, non-standard location of jets and for multiple dimensions. Part tolerances of .0005 or below require the addition of a "vee" backstop for part centering. A plastic hose with swivel fittings is required. Please include part print and complete information with your inquiry.

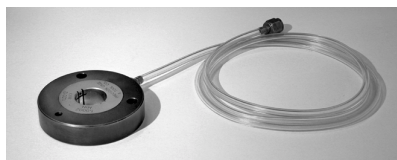
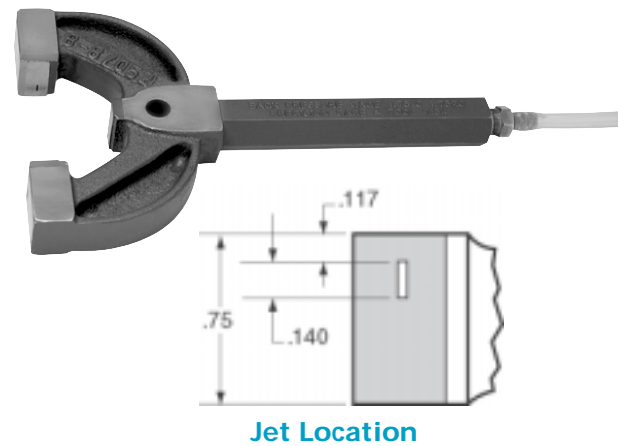

Air Rings

Air Rings are used to inspect the true or average outside diameter of cylindrical parts and can reveal conditions of cloverleaf, taper or out-of-roundness. They are manufactured in many different types, shapes, and sizes and can be designed for presenting the part to the gage or the gage to the part. They can be used with Precisionaire or A/E Column Instruments.

Air Rings are made of long wear life steel and can be chrome plated or TiN coated for even longer durability. A part print, sample part or any special requirements should be submitted with an inquiry.

Standard Thru and Shoulder Type Air Rings

Standard hand held Thru and Shoulder Type Air Rings cover a range of parts from .240 through 6.010. Thru Type Air Rings feature two diametrically opposed air jets centered in the ring. Shoulder Type Air Rings have the two jets located as close to the edge of the air ring as possible. Where "clover leaf" conditions exist, three-jet air rings are available for checking average diameter. For part-to-gage applications, a gaging stand is used.

Standard Setting Discs and Rings

Master Setting Discs

Standard American Gage Design (A.G.D.) Master Setting Discs for calibrating Air Rings and Airsnaps with Precisionaire and A/E Electronic Column Instruments are available in sizes .105 through 6.010. Larger sizes are available upon request. A.G.D. Style No. 1 is available in all sizes; A.G.D. Style No. 3 is recommended for sizes over 1.135.

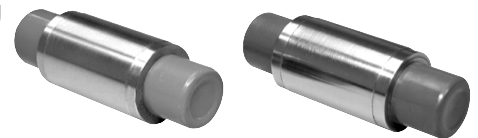

Master Setting Rings

Standard A.G.D. Master Setting Rings for calibrating air spindles with Precisionaire and A/E Column Instruments are available in sizes .040 through 4.760, with larger sizes available upon request.

Important notes on Master Setting Discs and Rings: Tolerance classes recommended for instrument calibration are X, XX, and XX calibrated. Gagemakers' tolerances are taken bilaterally, unless otherwise specified. (Tolerance is split plus and minus from nominal size.) Standard materials are

steel, hard chrome plating or solid tungsten carbide. Discs and Rings with certification of calibration are required for set up of Electronic Instruments with digital readouts.

Nominal Size Inches		Gagemakers' Tolerances Classes	
Above	To & Incl.	X	XX
.040	.825	.00004	.00002
.825	1.510	.00006	.00003
1.510	2.510	.00008	.00004
2.510	4.510	.00010	.00005
4.510	6.510	.00013	.000065
6.510	8.010	.00016	.00008

When ordering, please send a detailed part print so that our application engineers can double check your requirements.

Sheffield A/E Column takes air gaging to new heights.

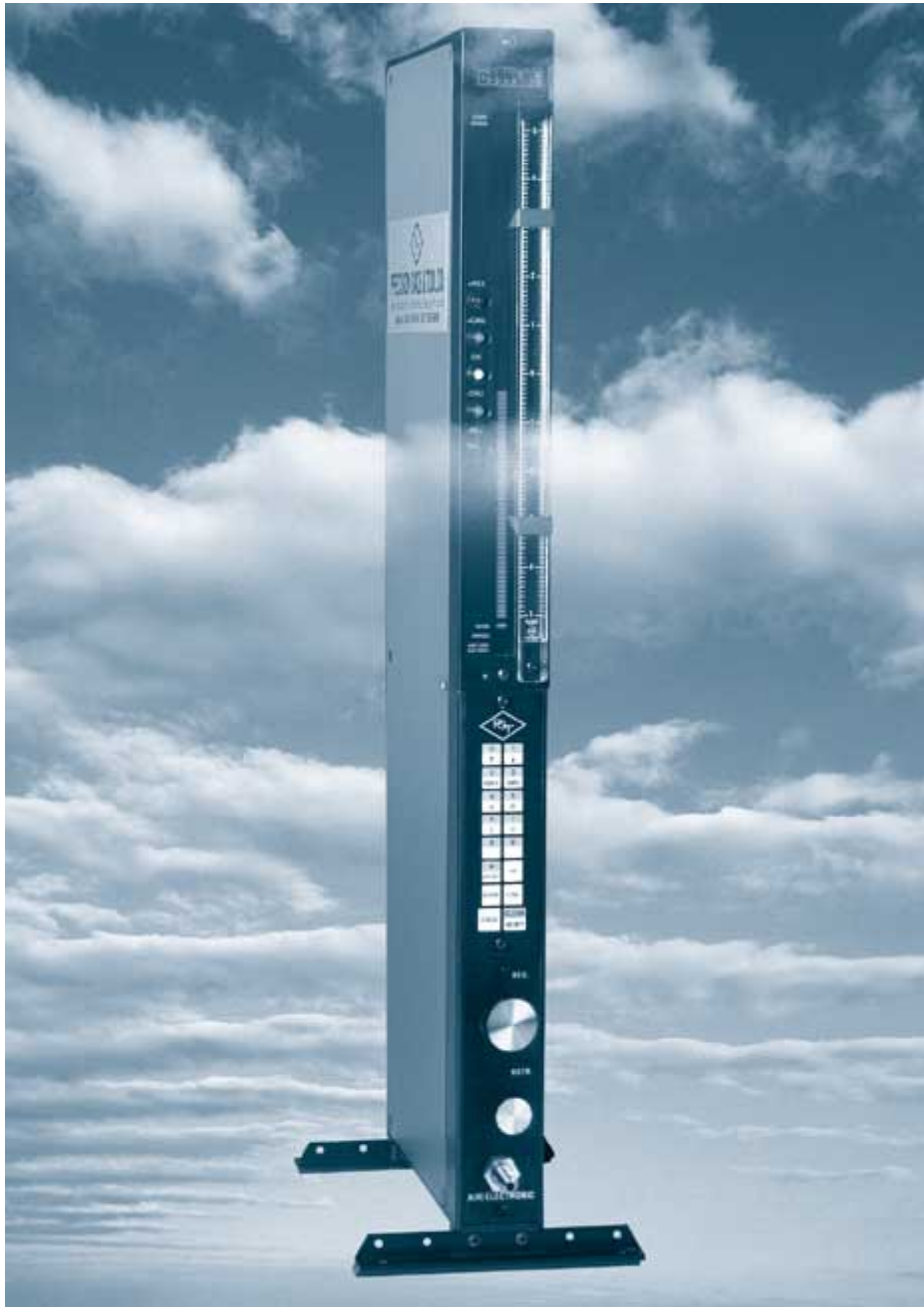

Couple the Precisionaire's reliable accuracy to the Electronic Column's modern technology, and the result is unsurpassed air gaging performance.

The Sheffield Air to Electronic (A/E) Column is a fast, easy-to-use instrument that gives you more precise control. It works with most existing air spindles, rings, snaps and fixtures. You get simple, automatic mastering, an electronic LED display and an actual size digital display. Plus output signals and a quick, stable, full-amplification response—all in a rugged column made for the shop environment.

The A/E Column is just one of our many economical solutions to your dimensional measurement problems. Precision Gage & Tool's Sheffield products combine fixtures, tooling, A/E Column, Electronic Column, air gage instruments, computer workstations and more to provide solutions to your unique needs—for less than a custom cost.

Call 937/866-9666 today for more details. Or visit www.precisiongage-tool.com.



PRECISION GAGE & TOOL CO.



Since its beginnings in 1929, Precision Gage & Tool Co. has maintained a leadership role in the manufacture of high-accuracy fineness of grind gages and film applicators for the worldwide ink and paint industries. Over the years, PGT has added to its capability with a line of specialized gaging equipment for railroads, and a variety of custom gages and fixtures for a broad range of industrial applications.

In 1998, PGT acquired the complete line of world renowned Sheffield gages, including Precisionaire[®], Micronaire[®] and electronic column systems, paper and bearing gages, air gage tooling, automatic and manual gaging fixtures and SOFT 2000 computer systems. With experienced Sheffield personnel on staff, PGT is your single source for Sheffield Gage engineering, sales and service.



PRECISION GAGE & TOOL COMPANY

375 Gargrave Road
Dayton, Ohio 45449
Phone: (937) 866-9666 Fax: (937) 866-9661
E-mail: pgt@precisiongage-tool.com
www.precisiongage-tool.com